

Moulder

Model 600-R3

Model 600-R35

Key Features:

- The 600-R3 moulder is designed for perfect shaping of rolls and various sizes of breads from 2 oz. (.1kg) to 6 lbs. (3kg)
- Output from 1,200 to 4,500 loaves per hour, depending on weight
- Accurate adjustment of sheeting via hand-operated levers with locking device
- Preliminary stretching between an endless rotating belt and a weighted belt
- Stretching between two endless belts rotating in opposite directions
- Three roller in-feed
- 600-R35 has synthetic belts



Manufactured in the U.S.A.

1/06

Oliver® Products Company :: 445 Sixth Street N.W. :: Grand Rapids, MI 49504-5298

Phone: 616/456-7711 :: Toll-Free: 800/253-3893 :: Fax: 616/456-7791

Web: www.oliverproducts.com/bakery :: Email: bakerysales@oliverproducts.com

Moulder

Model 600-R3

Model 600-R35

Specifications:

Motor:

3/4 H.P., 3 phase, 60 Hz, 220-240 VAC, 3.1 AMPS
Special electrics also available

Capacity:

2 oz. (.1kg) to 6 lbs. (3kg) loaves

Dimensions:

Shipping weight:

Without legs: 485 lbs. (220kg)

With legs: 525 lbs. (238kg)

Net weight:

Without legs: 285 lbs. (128kg)

With legs: 320 lbs. (144kg)

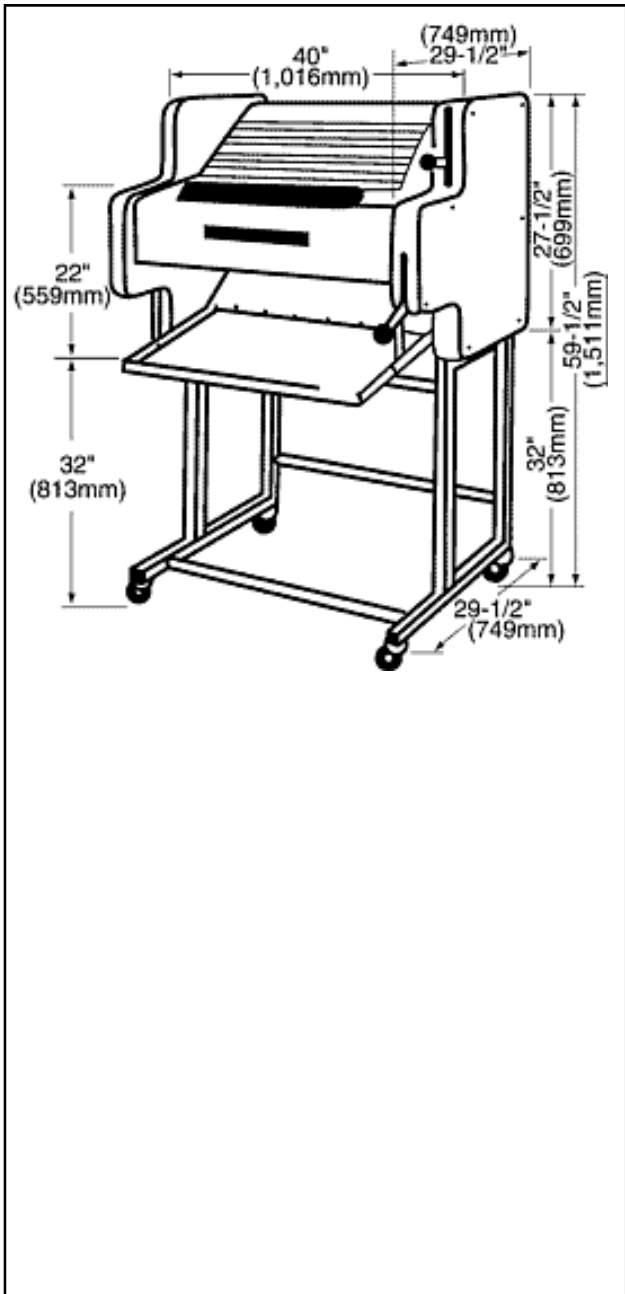

Above specifications subject to change without notice.

The information contained herein is correct to the best of our knowledge. The recommendations or suggestions are made without guarantee or representation as to results. Freedom from any patent owned by Oliver Products Company is not to be inferred.
Printed in U.S.A. ® Trademark of Oliver Products Company

Oliver® Products Company :: 445 Sixth Street N.W. :: Grand Rapids, MI 49504-5298

Phone: 616/456-7711 :: Toll-Free: 800/253-3893 :: Fax: 616/456-7791

Web: www.oliverproducts.com/bakery :: Email: bakerysales@oliverproducts.com